

Sport Boats / Semi-rigids

Leroni
Trailers Limited

Sunway

Single Axle

2011

G380M08 / G510M08

G550M08 / G650M08 / G710M08

G820M08 / G1000M08 / G1260M08

General Specification:

Hot dipped galvanised chassis, with adjustable galvanised sliding axle(s) for better balancing, EEC 94/20 approved coupling system, fully adjustable winch post (where fitted), Steel galvanised and painted mudguards, Multi-roller system adjustable for different hulls and are self aligning, lashing points, keel rollers, adjustable length lighting board, protected lights, jockey wheel.

Model	Gross Weight Kgs	Payload Kgs	Max Hull Length mtr.	Braked	Tyres	Price € (Incl. VAT)
G380M08	499	380	4.30	No	500 x 10	€1,070.00
G510M08	690	510	5.00	No	155/70 R13	€1,330.00
G650M08	900	650	5.40	Yes	175/70 R13	€2,190.00
G710M08	1000	710	5.50	Yes	185/70 R14C	€2,330.00
G820M08	1100	820	5.60	Yes	165 R14C	€2,450.00
G1000M09	1300	950	6.10	Yes	165 R14C	€2,760.00
G1260M08	1600	1260	6.30	Yes	185/70 R14C	€3,180.00
G1340M09	1800	1340	6.40	yes	195R14C	€3,510.00

Trailers over 750 Kgs gross will require Brakes
The Payload per trailer may vary depending on options fitted
The Manufacturer and their agents reserve the right to change the specifications and Prices without notice

Features

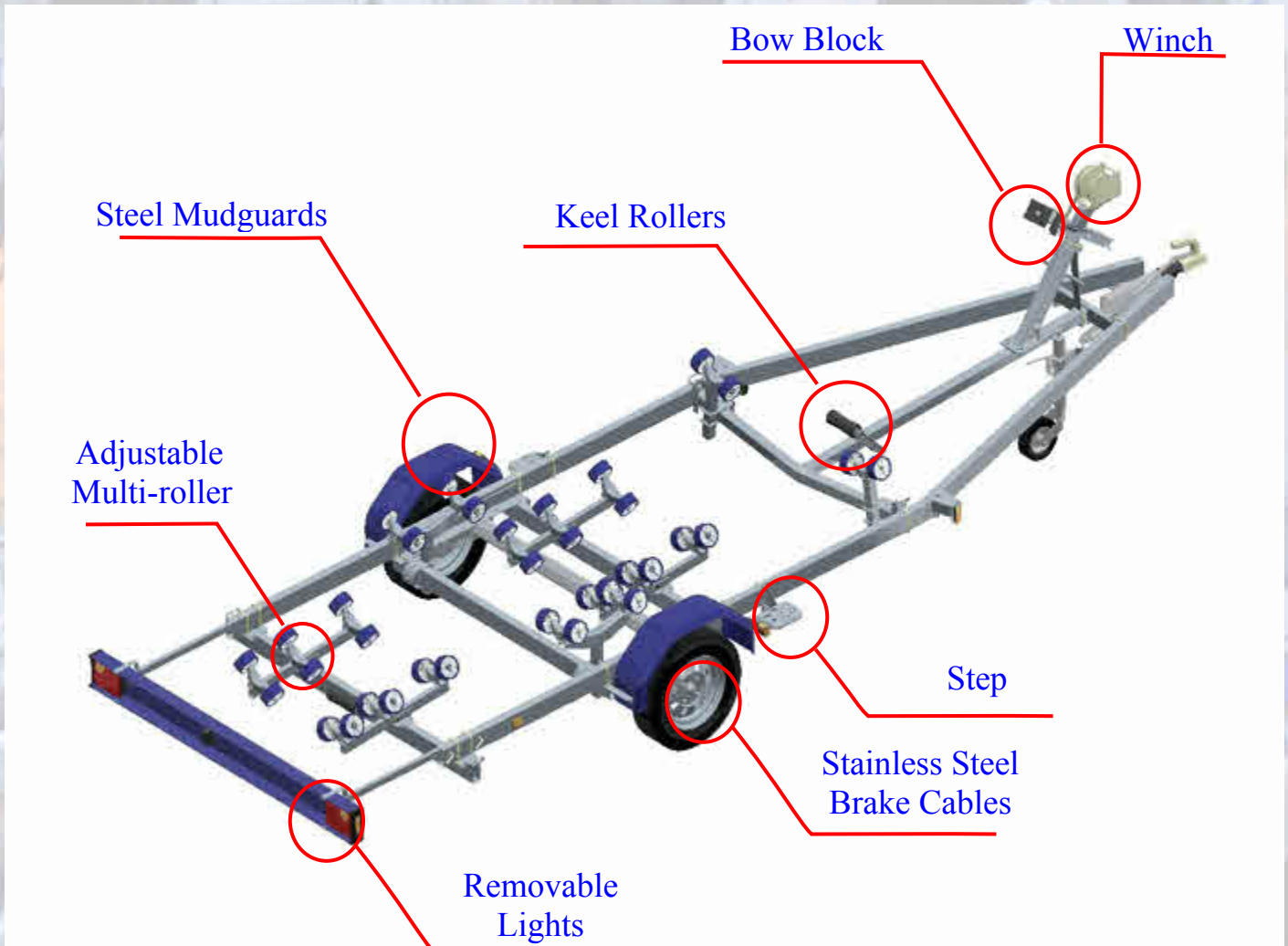

Sun way

Rue des Pierres
53960 BONCHAMP-LES-
LAVAL
FRANCE
Tél : 02.43.02.10.68

Leroni
Trailers Limited

Importers.

Leroni Trailers Ltd., Dunshauglin, Co. Meath.
☎046-9052101 or 086-8073379
email: info@leroni.ie web: www.leroni.ie